



JX 2300

Manuel utilisateur

Release 2.0

Ce document est sujet à modifications sans préavis
Si nécessaire, demandez la dernière version à : contact@flashelek.com

Table of contents

1	Generals.....	3
2	Physical wiring.....	3
2.1	Mains.....	3
2.2	Time Base sequence.....	4
2.3	Commands.....	5
3	Setting up.....	7
4	Technical specifications.....	9
5	Wiring.....	9
6	Packing.....	9
7	Spare parts.....	10

1 Generals

The JX 2300 set has to be used in conjunction with a PAR 56 Type Flash lamp (2000V typ.)

In this case it complies with ICAO Annex 14 recommendations.

The JX 2300 can be used to realise SFLS cat I and cat II/III with and without RTIL.
It also can be used as RTIL only, ODALS and Helipad approach.

2 Physical wiring

2.1 Mains

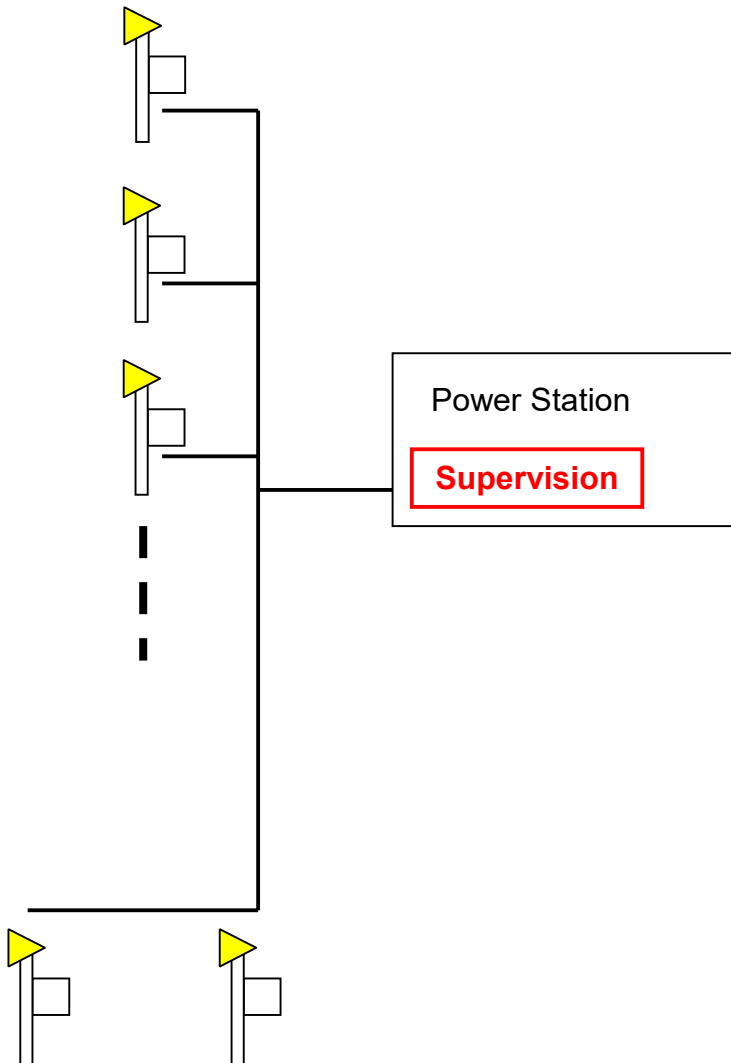

The Power Station supplies the sets with main 230V AC +/- 10 % (Black wire on diagram).

The mains cable have to be able to supply 0,5 rms A (230 V AC) or 1 rms A (110 V AC) for each flash lamp.

This power supply is switched on and off to command the flash boxes.

When an eventual heater resistor have to be supplied, a special mains line have to be installed. In this case, a tri-phased earthed cable have to be used. Insure hat the phases 2 are used for even sets, and phase 3 for odd ones.

The Supervision system will be in charge of switching On and Off the flashes by applying the mains.

2.2 Time Base sequence

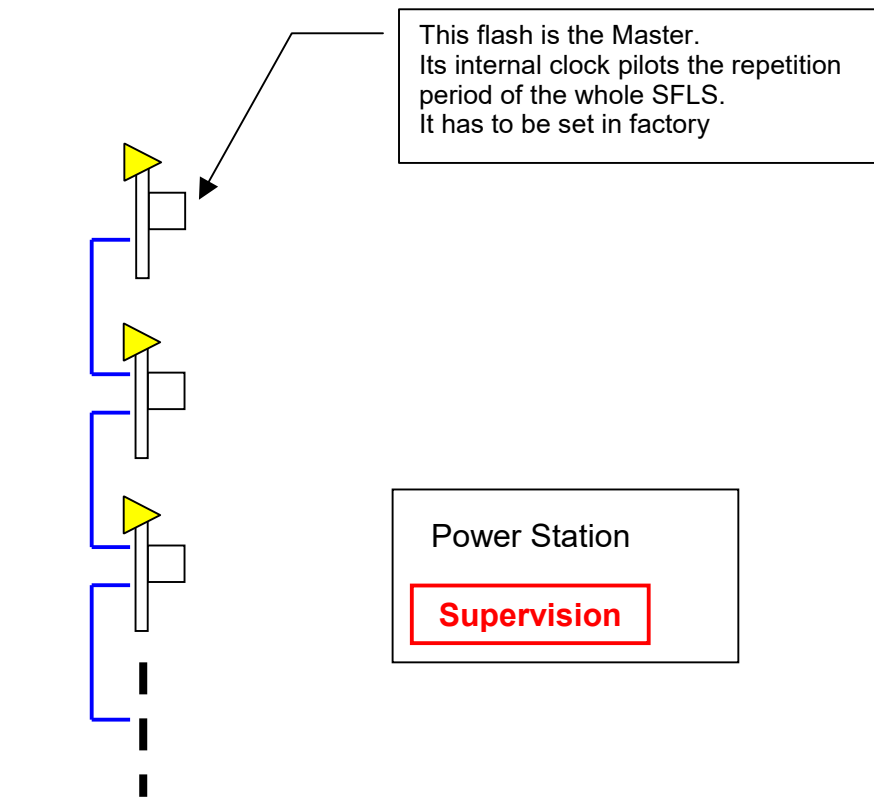

The sets are hierarchically sequenced via an unique analog time base line (clock signal, blue wire on diagram)

This signal passes through single shielded wire.

Each clock top is at least 30V_{pp} pulse of 2,5 ms duration.

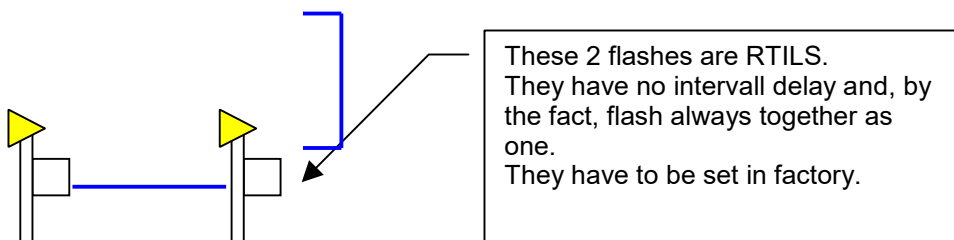

2.3 Commands

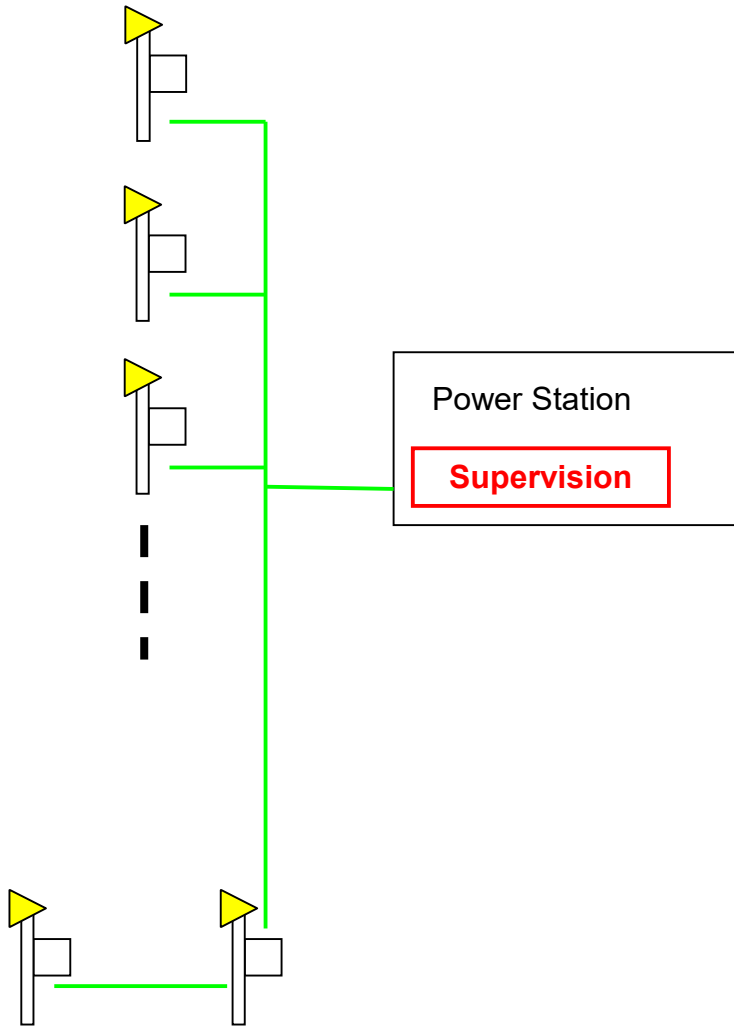

The sets are monitored via 3 analog wires and controlled via a current loop for complex systems or two analog wires for simple systems. (Green wire on diagram)

The controlling possibilities consists of switching the brilliance level by applying a 24 V DC or 48 V DC on the two remote control wires.

No command turns on Low Intensity
 MI command turns on Medium Intensity
 HI command turns on High intensity

The monitoring possibilities consists on two different way to be chosen :

- Simple systems (as REILS only) : Two wires are short circuited by the defective supply box (see next page)
- On SFLS systems, it is recommended to use the current loop capabilities as explained below.

A 13 mA typ. DC current flows all through the supply boxes. When each box have measured that the lamp has really flashed, it open the loop during a time of 10 ms.

The last supply box open the loop during a time of 15 ms, and this will able the supervision automat to count the total number of supply boxes installed.

The master box open the loop during a time of 5 ms, before its normal “top” of 10 ms previously mentioned, and this will able the supervision automat to reset on the master box info (first in the line) when an other box is defective.

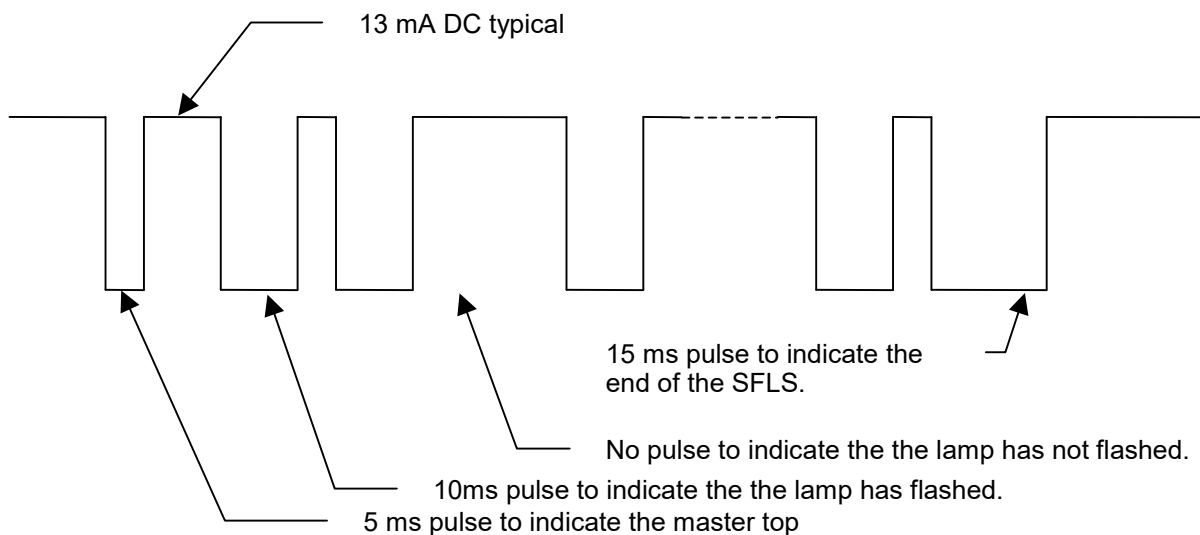

In case of small installations (i.e. REILS systems), an alarm signal is provided by closing a relay contacts when a box is faulty. These contacts are available on pin 7 and 8 of the outer connector (see JX2300 Outer Box connection manual for details)

To display this info, please connect an indicator as follow :

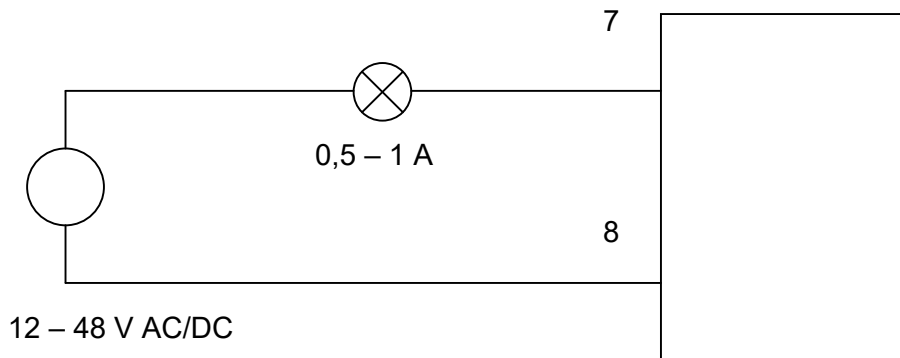

3 Set up

The micro switches on the clock panel are configured in factory. Anyway in case of interchange of the boxes, follow this table to insure the correct setting up.

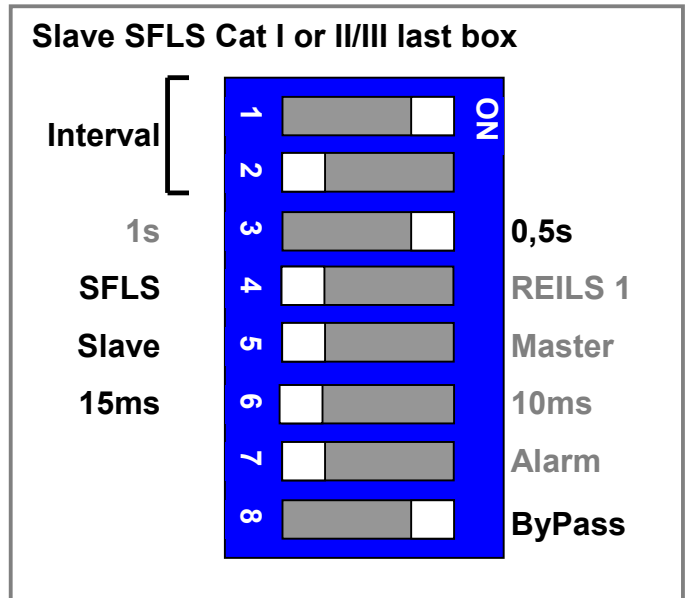
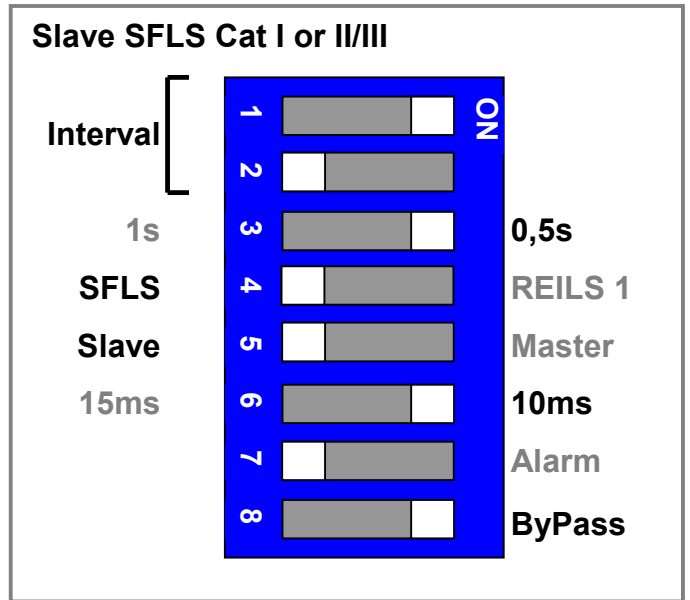
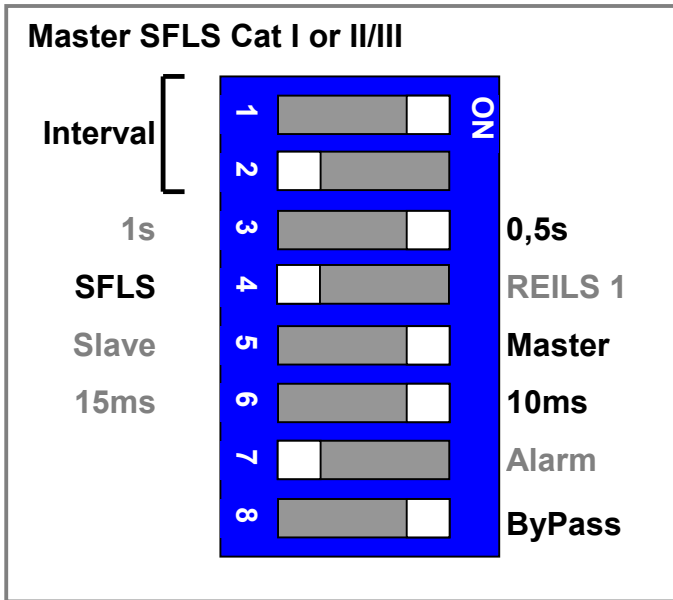

REILS1 of SFLS Cat I or II/III

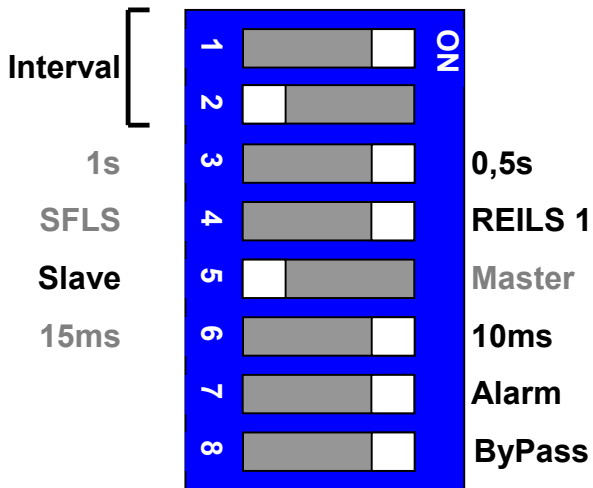

REILS2 of SFLS Cat I or II/III

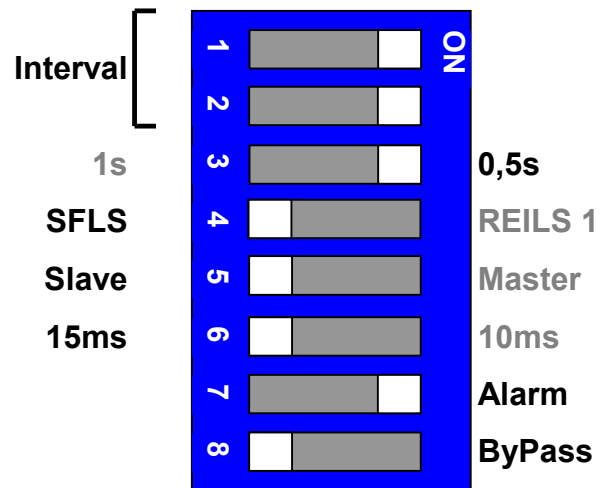

REILS1 : REILS only

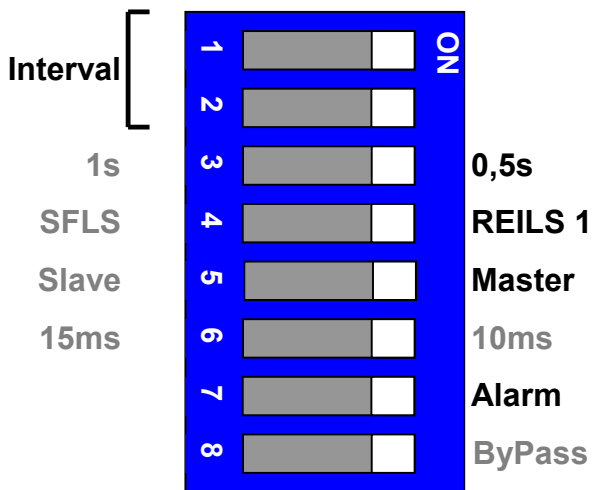

REILS2 : REILS only

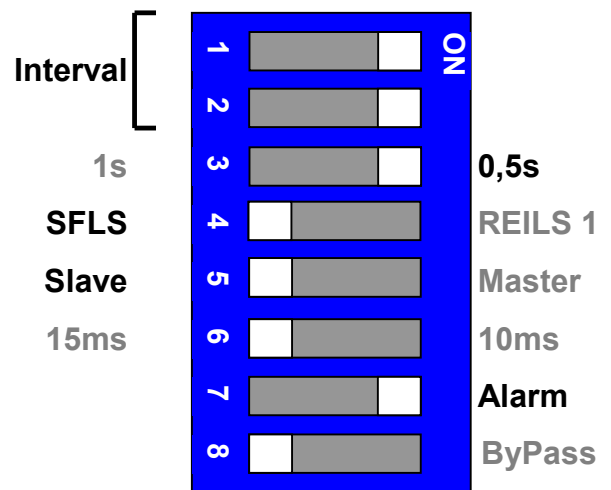

4 Technical specifications

Power supply	230V AC (+/- 10%) 50 Hz (110V AC 60Hz on demand)
Repetition period	0,5s – 1s (set in factory, these values can be changed on site manually)
Inter-flash delay	14 ms – 67 ms – 267 ms (set in factory, these values can be changed on site manually)
Brilliance levels	High intensity 100% (day mode) Medium intensity 10% (crepuscular mode) Low intensity 3% (night mode) (these values can be changed on site according to § 2.3)
Power consumption	150 VA typ.
Cos φ	Higher than 0,95
Efficiency	Higher than 80%
Working temperature range	-25°C to 55°C Outer boxes may be equipped with a heater resistor for very low temperature or particularly high moisture
External dimensions	H 350 mm x W 300 mm x D 172 mm

5 Wiring

For wiring details, see the Outer Box connection manual

6 Packing

Each set is delivered with an OuterBox connector	H 320 mm x W 440 mm x D 280 mm
Weight	8 kg

7 Spare parts

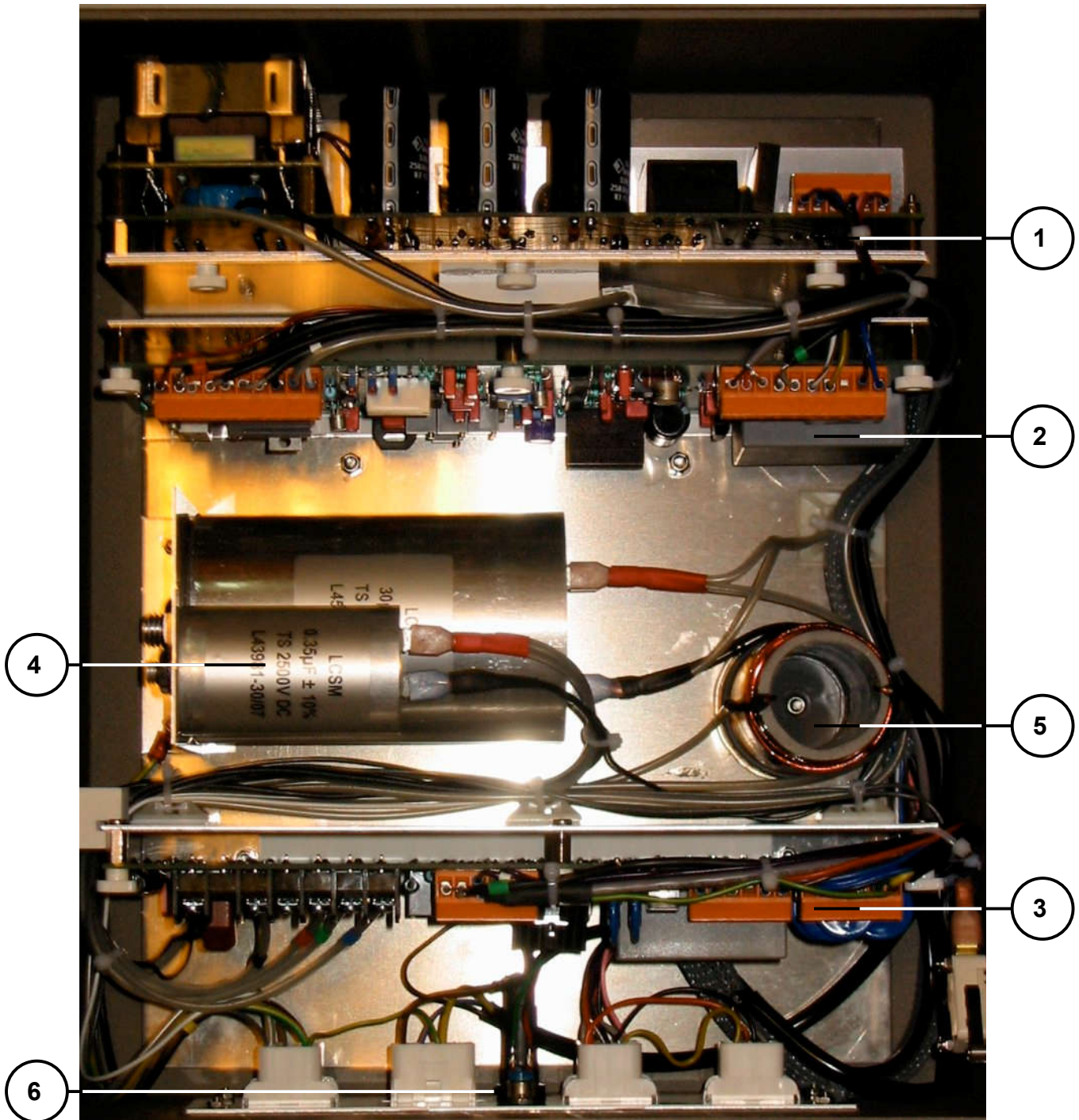

		Order Code
1	Power Supply	30 94 00
2	Clock Panel	30 02 09
3	Auxiliary Panel	30 94 02
4	Set of capacitors	31 00 30
5	Power coil	41 00 20
6	Set of fuses (by 5)	31 00 05